

Standard and Optional Equipment

Standard Equipment

- The operator / truck interface
 - Short tiller with high mounting point and middle head made out of Grivory®
 - Storage compartments
 - OptiLift® system
- Multifunction display with hourmeter, maintenance indication, battery discharge indicator and internal fault code indication Key switch or LFMgo (PIN-code access)
- AC motor
- Linde LAC controller
- CAN-bus architecture
- Electromagnetic brake
- Automatic parking brake
- Cushion rubber drive wheel
- Tandem polyurethane load wheels
- Fork length: 1150 mm
- Width over forks: 560 mm
- Protection to -10°C
- Vertical 2PzS BS battery change (L10P, L12P)
- Vertical 3PzS BS battery change (L14P)
- Horn
- Creep speed control (L12P, L14P)

Optional Equipment

- Drive wheels: polyurethane, non marking cushion
- Alternative fork lengths and widths
- Load backrest
- Fleet management LFMaccess and LFMbasic
- Creep speed control (L10P)
- Cold store protection to -35°C
- Automatic battery watering system



Stand-on Electric Pallet Stackers 1000, 1200, 1400kg

1169

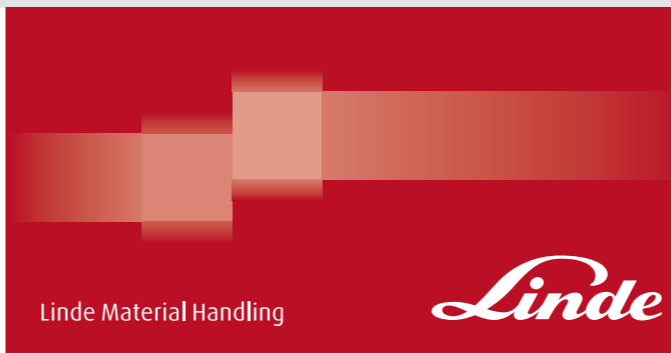

Safety

Three-way braking system: automatic braking by LBC on releasing travel control switch; Electromechanical braking when tiller is moved fully up or down; Electronic braking by reversing travel control switch. Emergency stop button interrupts all electric circuits and actuates electromechanical brake.

Performance

The combination of AC motor and Linde LAC digital control makes these pallet stackers highly efficient. Operating parameters can be adjusted to match any application. The OptiLift® mast control provides accurate, fully proportional lifting and assures quiet smooth operation.

Comfort

High position design short tiller provides easy operation, comfortable steering force reduces the operation fatigue during frequent steering. Through Sinergo®, all controls on the ergonomic tiller can be easily operated by either hand. A Creep speed button offers utmost maneuverability in confined areas.

Reliability

Despite their visual appeal, these pallet stackers are rugged and durable. The mast channels are made from high grade rolled steel sections for strength and durability. Grivory® tiller head is strong, non-deformable and longlasting.

Service

It is not just about the truck in operation: a maintenance-free AC motor maximises uptime reducing operating costs. All truck data is immediately and easily accessible to the service engineer via the CAN-bus architecture. Fast, easy access to all internal components ensures service tasks are completed with a minimum of delay.

Features

Steering system

- Suitable steering force reduces the fatigue during long term working time
- A Creep speed button ensures high manoeuvrability in confined areas when operating at low speeds with the tiller in the upright position

Lifting system

- OptiLift® mast control provides accurate, fully proportional lifting as well as smooth, quiet operation
- Wide range of mast options available

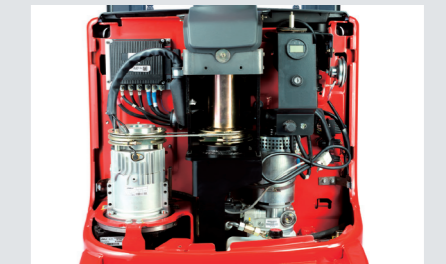

Rider stand platform

- Platform suspension absorbs vibration and shock
- Soft mat platform for high operator comfort
- Suitable platform height design can easily fold up and down

Tiller & tiller head

- New Grivory® tiller head ensures comfortable
- High position design short tiller provides easy operation
- Wrap-around hand operation
- Comfortable controls, operable with either hand and gloves

Maintenance and Can-bus architecture

- Zero maintenance, moisture and dust-proof
- AC motor
- CAN-bus architecture enables fast, easy access to all truck data
- Individually adjustable parameters via diagnostic plug
- Rapid and convenient access to main components via front service panel

Other options available on request

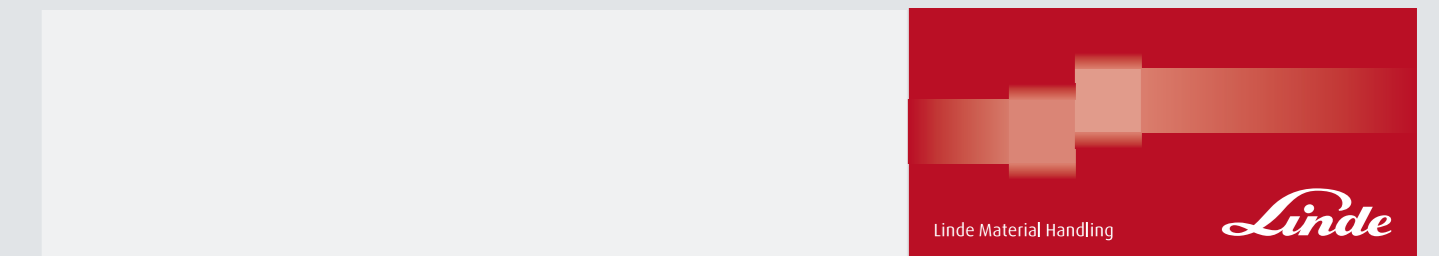

Subject to modification in the interests of progress. Illustration and technical details not binding for actual constructions and may show the optional equipments.

1169_L10P;L12P;L14P_D-01_201312

Technical Data

Characteristics	1.1	Manufacturer	Linde	Linde	Linde	
	1.2	Model designation	L10P	L12P	L14P	
	1.3	Power unit	Battery			
	1.4	Operation	Pedestrian/Stand on			
	1.5	Load capacity	Q(kg)	1000	1200	1400
	1.6	Load center	c(mm)	600	600	600
	1.8	Axle centre to fork face (fork raised/lowered)	x(mm)	665 ¹⁾	665 ¹⁾	665 ¹⁾
	1.9	Wheelbase (fork raised/lowered)	y(mm)	1157 ¹⁾	1157 ¹⁾	1245 ¹⁾
	Weights	2.1	Service weight (with battery item 6.5)	kg	1030 ²⁾	1030 ²⁾
2.2		Axle load with load, drive/load side	kg	915/1300	925/1300	985/1540
2.3		Axle load without load drive/load side	kg	750/270 ²⁾	760/270 ²⁾	810/320 ²⁾
Wheels	3.1	Tyre, operator/load side: Rubber(R), polyurethane (PU)		R+PU/PU	R+PU/PU	R+PU/PU
	3.2	Tyre size, drive side	mm	Ø 230x75	Ø 230x75	230x75
	3.3	Tyre size, load side	mm	Ø 2x85x80	Ø 2x85x80	2x85x80
	3.4	Auxiliary wheel, size	mm	140x54	140x54	140x54
	3.5	Wheels number, drive/load side (x=driven)		1X+1/4	1X+1/4	1X+1/4
	3.6	Track width, drive side	b10(mm)	518 ¹⁾	518 ¹⁾	518 ¹⁾
	3.7	Track width, load side	b11(mm)	380 ¹⁾	380 ¹⁾	380 ¹⁾
Dimensions	4.2	Height of mast, lowered	h1(mm)	1990 ¹⁾	1990 ¹⁾	1990 ¹⁾
	4.3	Free lift	h2(mm)	150 ¹⁾	150 ¹⁾	150 ¹⁾
	4.4	Lift height	h3(mm)	2924 ¹⁾	2924 ¹⁾	2924 ¹⁾
	4.5	Height of mast, extended	h4(mm)	3452 ¹⁾	3452 ¹⁾	3452 ¹⁾
	4.6	Initial lift	h5(mm)	-	-	-
	4.9	Height of tiller arm in operation position, min./max.	h14(mm)	1233/1433	1233/1433	1233/1433
	4.15	Fork height, lowered	h13(mm)	85	85	85
	4.19	Overall length	l1(mm)	2315 ¹⁾	2315 ¹⁾	2407 ¹⁾
	4.20	Length to fork face	l2(mm)	1165 ¹⁾	1165 ¹⁾	1257 ¹⁾
	4.21	Overall width	b1/b2(mm)	800 ¹⁾	800 ¹⁾	800 ¹⁾
	4.22	Fork dimensions	s/e/l(mm)	60x180x1150	60x180x1150	60x180x1150
	4.24	Width of fork carriage	b3(mm)	780	780	780
	4.25	Fork spread, min./max.	b5(mm)	560	560	560
	4.32	Ground clearance, center of wheelbase	m2(mm)	30	30	30
	4.33	Aisle width, 1000x1200mm pallet crosswise	Ast(mm)	2749/2483 ³⁾	2749/2483 ³⁾	2833/2632 ³⁾
4.34	Aisle width, 800x1200mm pallet lengthwise	Ast(mm)	2768/2502 ³⁾	2768/2502 ³⁾	2852/2651 ³⁾	
4.35	Turning radius (fork raised)	Wa(mm)	1881/1615 ³⁾	1881/1615 ³⁾	1965/1764 ³⁾	
Performances	5.1	Travel speed, with/without load	km/h	6.0/6.0 ⁴⁾	6.0/6.0 ⁴⁾	6/6 ⁴⁾
	5.2	Lift speed, with/without load	m/s	0.09/0.18	0.12/0.25	0.14/0.28
	5.3	Lower speed, with/without load	m/s	0.23/0.17 ²⁾	0.23/0.18 ²⁾	0.25/0.21 ²⁾
	5.8	Maximum climbing ability, with/without load, 5 min. rating	%	5/10	5/10	5/10
	5.9	Acceleration time, with/without load	s	8.2/7.3	8.2/7.3	7.9/7.2
	5.10	Service brake		Electro-magnetic		
Drive	6.1	Drive motor output (60 min.rating)	kw	1.2	1.2	1.2
	6.2	Lift motor output (15% rating)	kw	1	2.45	2.45
	6.3	Battery according to DIN 43 531/35/36A, B, C, no		DIN 43531/35/36 A, B, C, no		
	6.4	Battery voltage/rated capacity (5h)	V/Ah	24/200	24/200	24/225
	6.5	Battery weight (± 5%)	kg	193	199	199
	6.6	Power consumption according to VDI cycle	kWh/h	0.75	1	1
	8.1	Type of drive control		LAC	LAC	LAC
	8.4	Sound level at driver's ear	dB(A)	65	65	65

Figures for standard version may vary when options equipment is fitted

- 1) (± 5mm)
- 2) (± 10%)
- 3) Solid rubber+polyurethane/polyurethane
- 4) (Calculated with the VDI guidelines 3579)
- 5) Platform foldable/unfoldable
- 6) (± 5%)

Load Capacity Diagrams:

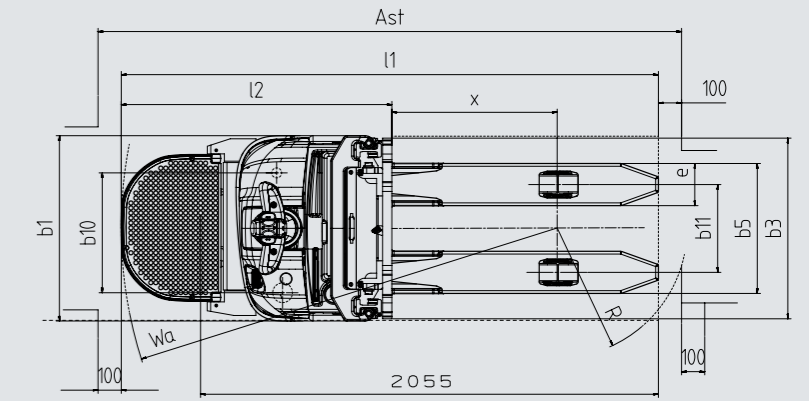
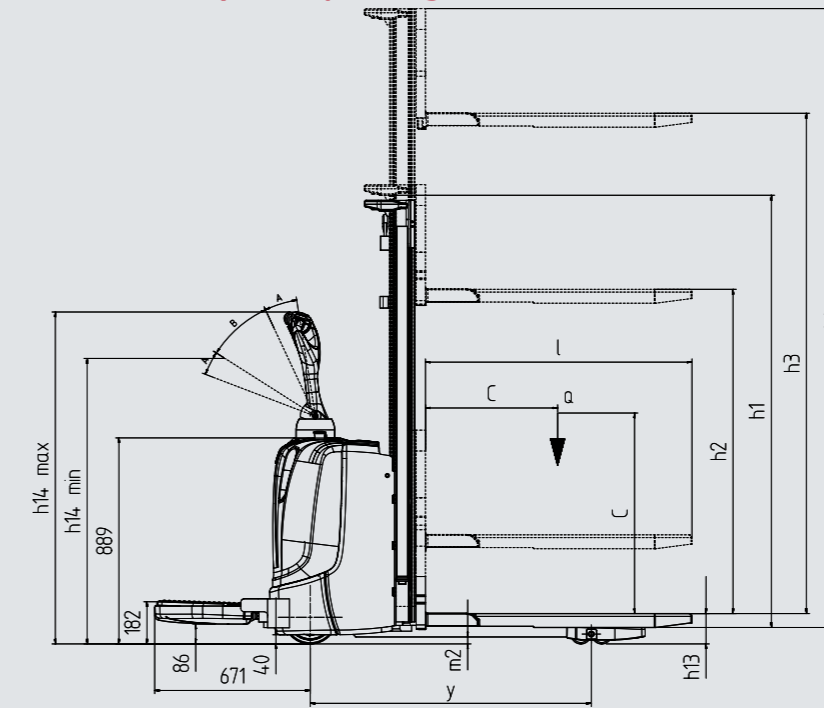

$$Ast = Wa \pm \sqrt{(l6 - x)^2 + \left(\frac{b12}{2}\right)^2} + a$$

Safety distance a=200mm

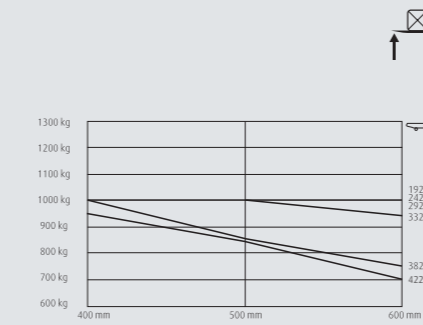

L10-560 S/D mast

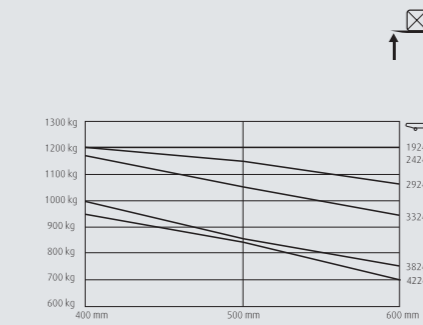

L12-560 S/D mast

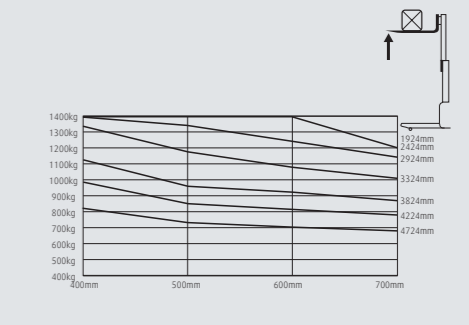

L14C-560 S/D mast

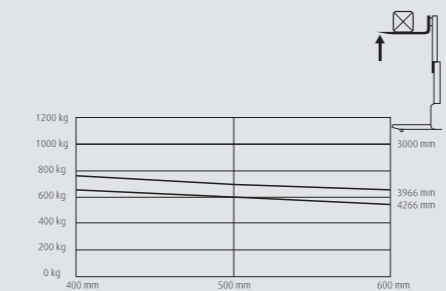

L10-560 T mast

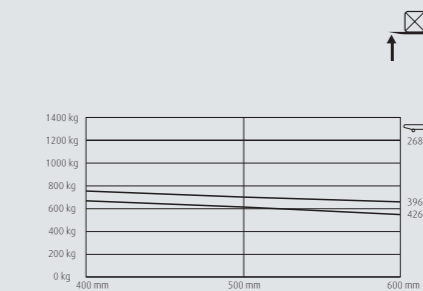

L12-560 T mast

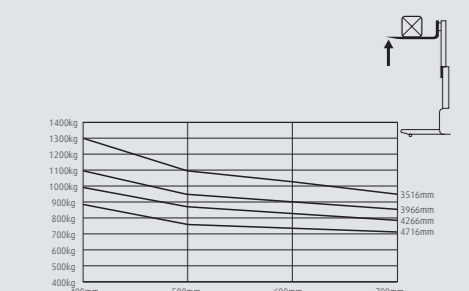

L14C-560 T mast

Mast Datasheet (in: mm)

Mast types: (L10/L12/L14C)			1924S	2424S	2924S	3324S	3824S	4224S	2924D	4266T
Lift	h ₃	mm	1924	2424	2924	3324	3824	4224	2924	4266
Lift+fork height	h ₃ +h ₁₃	mm	2010	2510	3010	3410	3910	4310	3010	4352
Height, mast retracted	h ₁	mm	1490 ¹⁾	1740 ¹⁾	1990 ¹⁾	2190 ¹⁾	2440 ¹⁾	2640 ¹⁾	1915	1915
Height, mast extended	h ₄	mm	2452	2952	3452	3852	4352	4752	3452	4852
Free lift	h ₂	mm	150	150	150	150	150	150	1462	1379